

LOC		DIST		P		F		ZONE		LTR		REVISIONS			
CM	53											DESCRIPTION	DATE	APPD	
												H	REV PER EC 0730-0210-95	2-9-96	RV

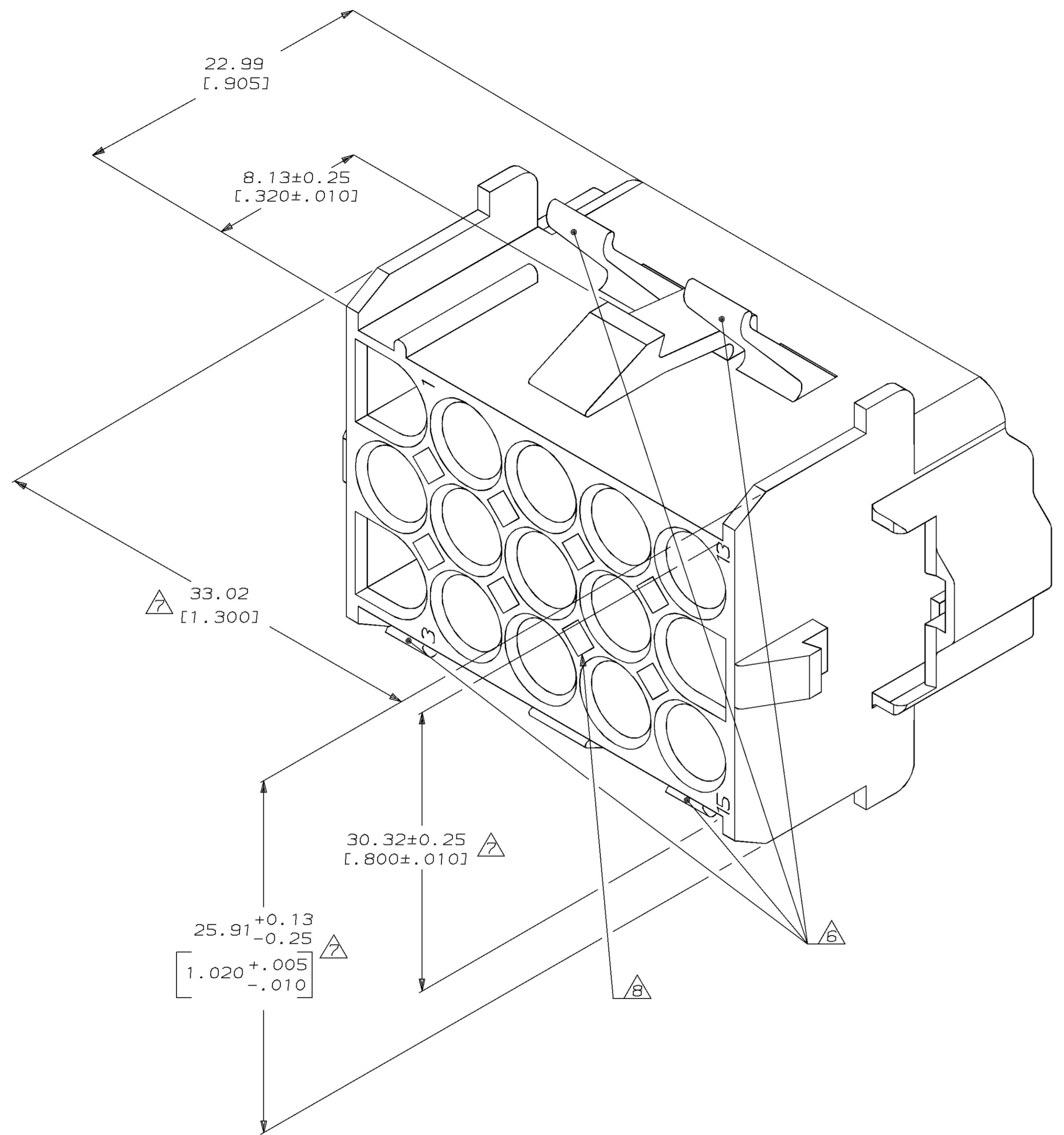

1. MUST BE ASSEMBLED WITH CAP REAR P/N 770058-1 BEFORE MATING. KIT P/N IS 770030-1.
2. RECOMMENDED PANEL THICKNESS 0.76-2.29 [0.030-.090].
3. PANEL MUST BE PUNCHED SO THAT THE HOUSING ENTERS THE PANEL IN THE SAME DIRECTION AS THE PUNCH.
4. OPTIONAL FOR KEYING HOUSING IN PANEL.
5. CIRCUIT NUMBER 1 LOCATION.
6. AMP LOGO LOCATED ONCE ON ANY INDICATED SURFACE FAR SIDE.
7. DIMENSION INDICATED IS AS MOLDED. ADDITIONAL GROWTH DUE TO SUBSEQUENT MOISTURE ABSORPTION MAY OCCUR.
8. OPTIONAL CONSTRUCTION PROVIDES ROUND MATERIAL REDUCTION CORING HOLES.

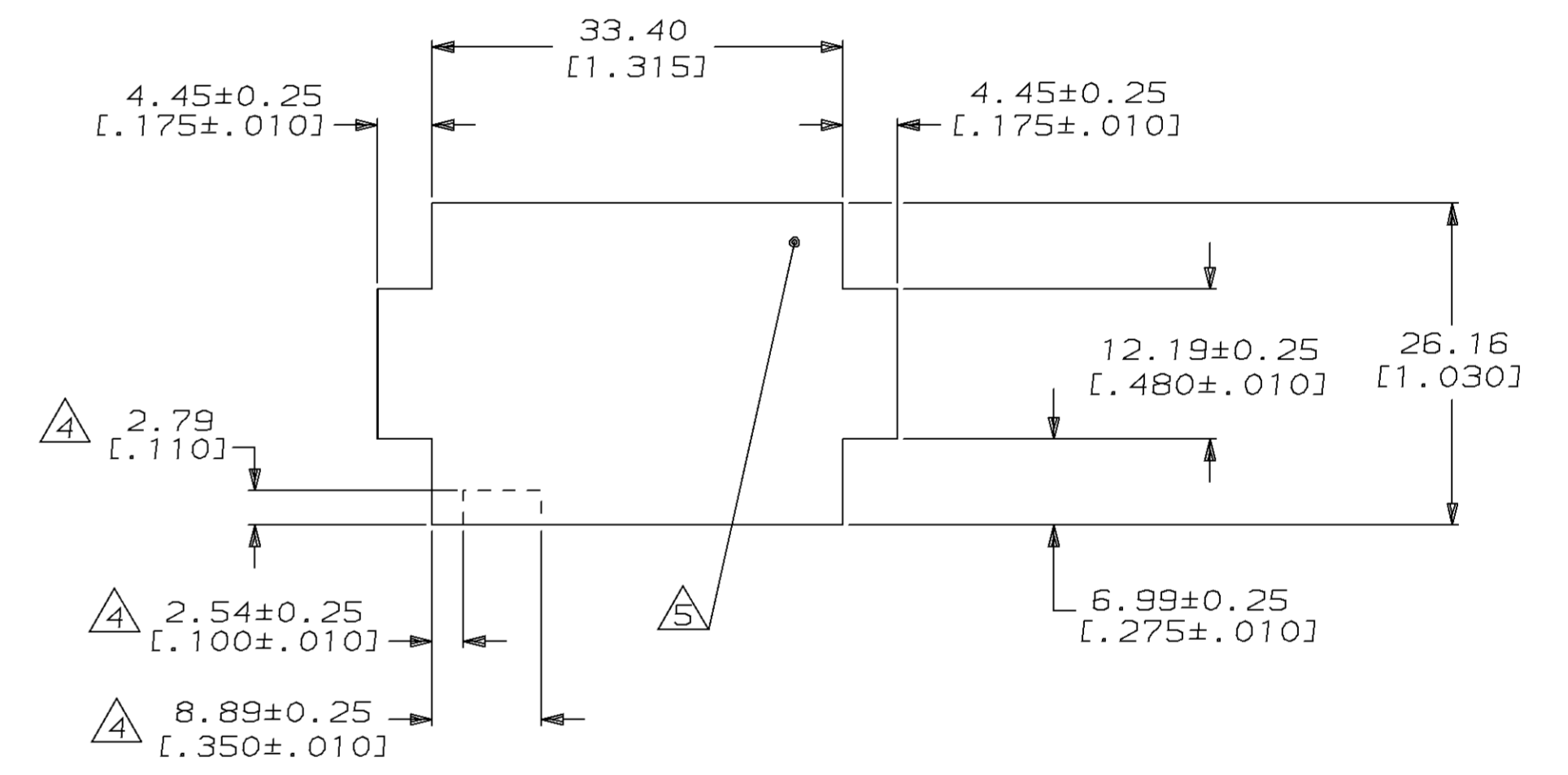

RECOMMENDED PANEL CUTOUT
 (HOUSING ENTRY SIDE)
 SCALE 2:1

770057-1
 PART NUMBER



DO NOT SCALE PRINT. UNLESS SPECIFIED DIMENSIONS IN INCHES TOLERANCES ON:		DR 1-15-92 K. SALMON		PART NO	
1. DIMENSIONS ON		CHK 1-15-92 R. SWING		AMP INCORPORATED Harrisburg, Pa. 17105	
2. PLC DEC ± 0.13 [±.005]		APPD 1-16-92 M. TRULL		NAME	
3. ANGLES ±		APPD 1-16-92 M. TRULL		CAP FRONT, 15 CIRCUIT, UNIVERSAL MATE-N-LOK™ II	
MATERIAL		PRODUCT SPEC		SIZE	
NYLON, UL94V-0,				D 00779	
FINISH		APPLICATION SPEC		DRAWING NO	
				770057	
WEIGHT		SCALE		FSCM NO	
		5:1		00779	
				DRAWING NO	
				770057	
				SHEET	
				1 OF 1	